

PIRANHA-125

/



Cardi s.r.l.
via Leonardo da Vinci, 21, I-24030 Pontida (BG), Italy
Tel. +39 035 795029
Fax +39 035 796190
www.cardi.biz



ADR
TECH
« - »
/ : (495) 150-0822
www.adr-t.ru
E-mail: info@adr-t.ru

7/8

1	3
2	3
2.1	3
2.2	3
2.3	3
2.4	3
2.5	3
3	4
4	4
5	5
5.1	(PH-125-U)	5
5.2	6
5.3	7
5.4	7
5.5	8
5.5.1	8
5.5.2	8
5.5.3	(PH-125-U)	8
5.5.4	PRCD (PH-125-U)	8
5.5.5	9
6	9
7	9
7.1	9
7.2	9
8	10
9	10

1

PIRANHA-125 (PH-125) –

PH-125-S

PH-125-U –

-
-
-
-
-
-
-
-



2

2.1

2.2





2.3

« »

2.4

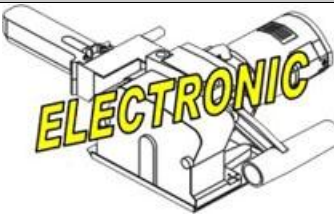
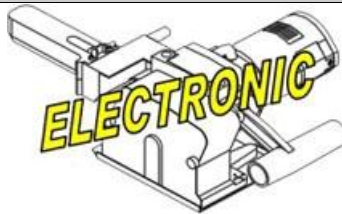
2.5

3

	PH-125-S	PH-125-U
	230	230
	50÷60	50÷60
	8,5	8,5
	1850	1850
	7900	7900
	5000	5000
	950	950
	9,5	9,5
	1040	1040
	2,2	2,2
		
PRCD (personal residual current device)		
		
	125	125
	1÷3	1÷3
	22,2	22,2
	38	38
	40	40
	6,5	6,5
	45	45
	E.P. 68÷150 cST ., ESSO Spartan E.P.68 ESSO Spartan E.P.150	E.P. 68÷150 cST ., ESSO Spartan E.P.68 ESSO Spartan E.P.150
	40	40

4

Cardi s.r.l.

EN 60745-1, EN 55014

- ✓ 2006/42/EC
- ✓ 2006/95/EC
- ✓ 2004/108/EC
- ✓ 2002/96/EC
- ✓ 2002/95/EC

EN 61029-1

85

91

101

<2,5 /².

Ezio Cattaneo 

5

5.1 (PH-125-U)

PH-125-U
 (,)
 (,)
 • 4 (4).
 •
 •
 •
 • – IP 55, . .



(,),

PH-125-U

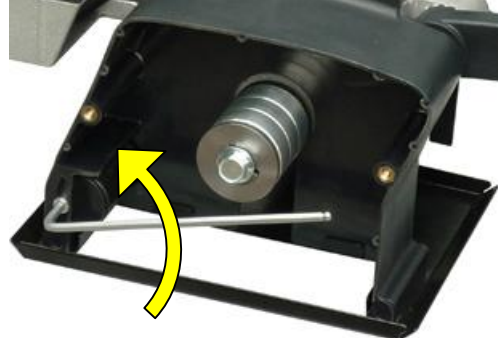
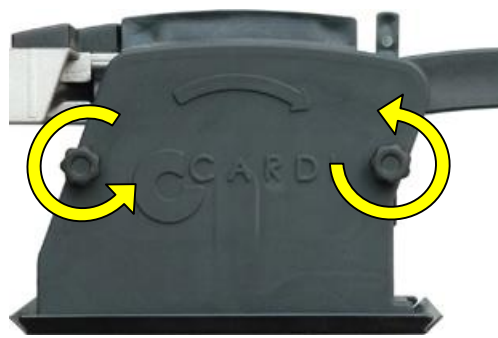

()

5.2

PH-125

(5000-8000 /).

(125),

(22,2)

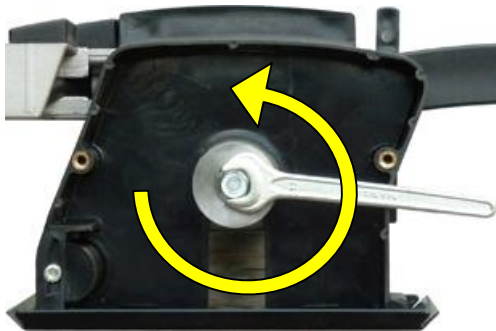
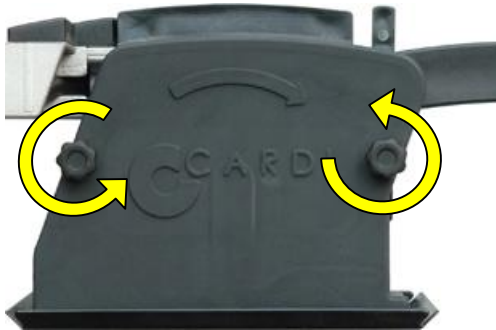

(2)

13,2

(1)

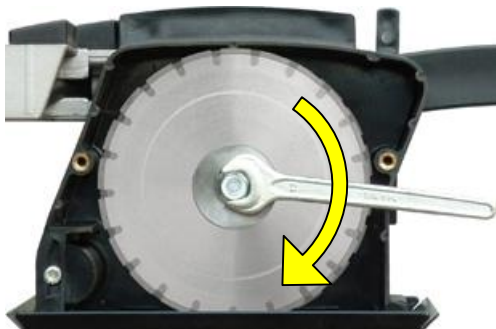

PH-125 – 3

5.3

PH-125

- 1.
- 2.

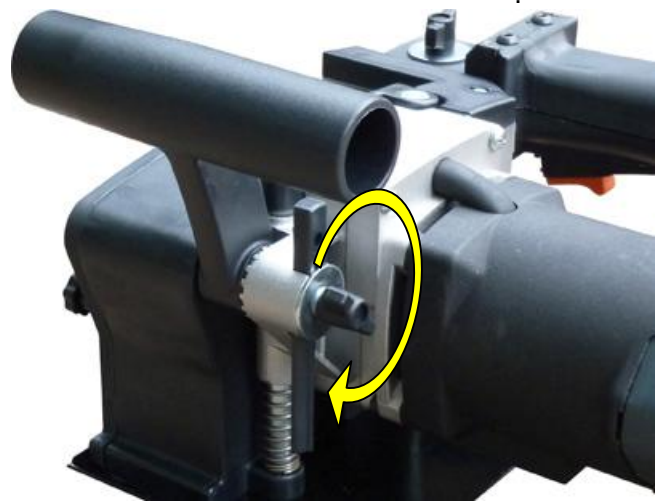
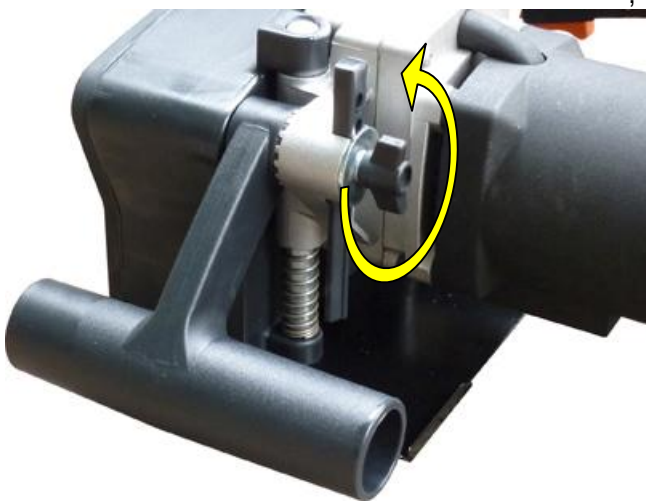
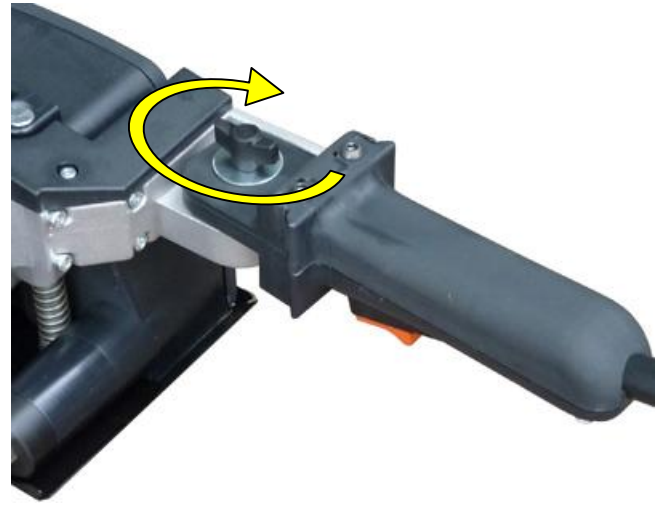
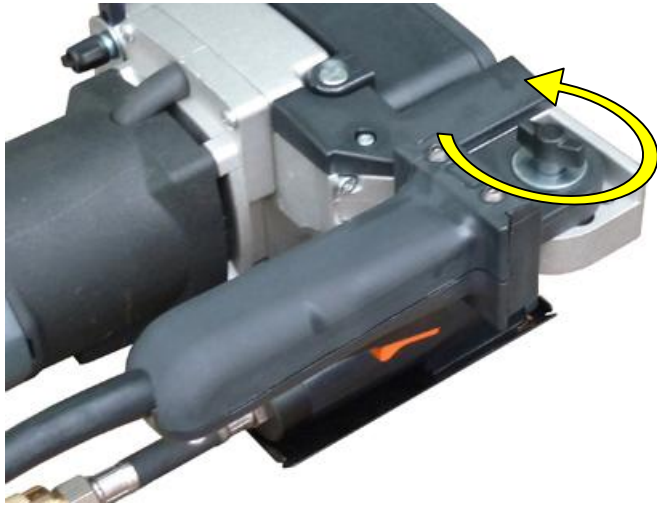

5.4

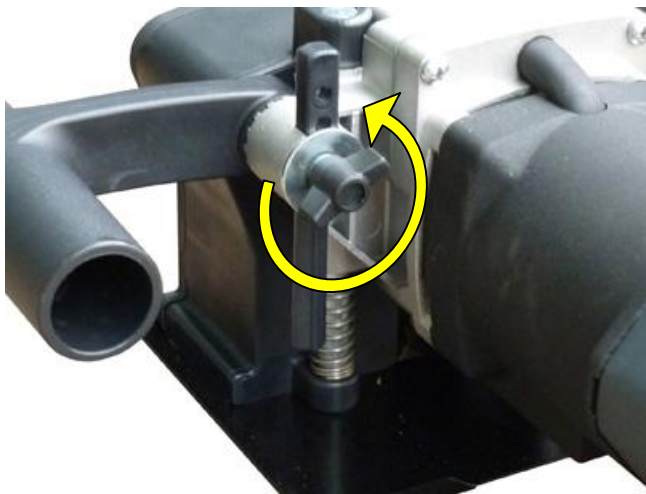

3

3

5.5

5.5.1

PH-125 1- 220-230 , 50-60 .



30%

210-240 .

5.5.2

- 45 - 2,5 2,
- 45-60 - 4,0 2,

PH-125-U



5.5.3

(PH-125-U)
PH-125-U



5.5.4

PRCD (PH-125-U)
PH-125-U

PRCD (personal residual current device),

PRCD.

«RESET».
«TEST». PRCD



«RESET»

PRCD

PRCD

«TEST»

PRCD,

PRCD,



PRCD

5.5.5

-
-

»

2-3

«



6



()



-
-
-

-
-

-
-

7

7.1

PH-125

7.2

PH-125

(2-3)

8

250

Cardi.

Cardi,

9

1.

24

2.

3.

3.1.

Cardi.

Cardi

3.2.

3.3.

6

3.4.

4.

5.

5.1.

.3.1.,

5.2.

5.3.

5.4.

5.5.

5.6.

5.7.

6.

7.

.1.